

Twin throttle-type check valve, directly operated

RE 27506-XC-B2/06.09
Replaces: 08.06

Type Z2FS 6...XC

Nominal size 6
Unit series 4X
Maximum operating pressure 315 bar
Maximum flow rate 80 l/min



TB0041

ATEX units
For potentially explosive atmospheres

Part II Technical Data Sheet



Information on explosion protection:

Range of application in accordance with the Explosion Protection Directive and type of protection

- Range of application as per Directive 94/9/EG IM2, II2G, II2D
- Type of protection of valve: c (EN 13463-5:2004-03)

What you need to know about these Operating Instructions

These Operating Instructions apply to the explosion-proof version of Rexroth valves, and consist of the following three parts:

- Part I General Information RE 07010-X-B1
- Part II Technical Data Sheet RE 27506-XC-B2
- Part III Product-specific Instructions RE 27506-XC-B3

RE 27506-XC-B0

You can find further information on the correct handling of Rexroth hydraulic products in our publication "General Product Information on Hydraulic Products", RE 07008.

Overview of Contents

Contents	Page
Features	2
Ordering data and scope of delivery	3
Function, sectional diagram	4
Symbols	4
Technical data	5
Information on explosion protection	5
Characteristic curves	6
Unit dimensions	7

Features

- Modular valve
 - Position of ports to ISO 4401-03-02-0-05 with tension pin and locating bore
 - Adjusting screw with lock nut and protective cap
 - For limiting the main or pilot flow of two consumer ports
 - For inlet or outlet throttling

Ordering data and scope of delivery

Z2FS	6		2	-4X/	-		XC	J	
------	---	--	---	------	---	--	----	---	--

Twin throttle-type check valve,
directly operated

Nominal size 6 = 6

Throttle-type check valve sides A and B = -
 Throttle-type valve side A = A
 Throttle-type valve side B = B

Setting element

Adjusting screw with lock nut and protective cap = 2

Unit series 40 to 49 = 4X
 (40 to 49: installation and connection
 dimensions unchanged)

Inlet throttling on sides A and B (...-4X/S) = S

Inlet throttling on side A (...A-4X/S)

Inlet throttling on side B (...B-4X/S)

Outlet throttling on sides A and B (...-4X/S2) = S2

Outlet throttling on sides A (...A-4X/S2)

Outlet throttling on sides B (...B-4X/S2)

No code = NBR-seals
 V = FKM-seals

Note:
 Take compatibility of seals and
 pressure fluid into account!

J = Sea-water protection

XC = Valve in explosion-proof design,
 see information on explosion protection,
 page 5, for details

1Q = With precision adjustment

2Q = Standard version

Included in scope of delivery:

Valve operating instructions with Declaration of Conformity
 in Part III

Function, sectional diagram

Type Z2FS 6...XC valves are twin throttle-type check valves with a modular design.

They are used to limit the main or pilot flow of one or two consumer ports.

Two throttle-type check valves positioned symmetrically to one another limit flows in one direction and provide a free return of fluid in the opposite direction.

With inlet throttling, the pressure fluid flows through the duct A1 to reach the consumer A2 via the throttling point (1), which is formed by the valve seat (2) and the throttling piston (3). The throttling piston (3) can be axially adjusted by means of the adjusting screw (4), thereby enabling the throttling point (1) to be adjusted as well.

The pressure fluid returning from the consumer B2 pushes the valve seat (2) against the spring (5) in the direction of the throttling piston (3), thereby enabling the fluid to flow unhindered from B2 to B1 via the check valve. The same applies to the flow in the opposite direction. Throttling may take effect in the inlet or the outlet, depending on the valve type.

Main flow limitation (version ..2Q..)

To change the speed of a consumer (main flow limitation), the twin throttle-type check valve is installed between the directional control valve and the subplate.

Pilot flow limitation (version ..1Q..)

The twin throttle-type check valve can be used to set the switching delay (pilot flow limitation) of pilot-operated directional control valves. In this case, it is installed between the pilot valve and the main valve.

Type Z2FS 6 -2-4X/S...XC (inlet throttling)

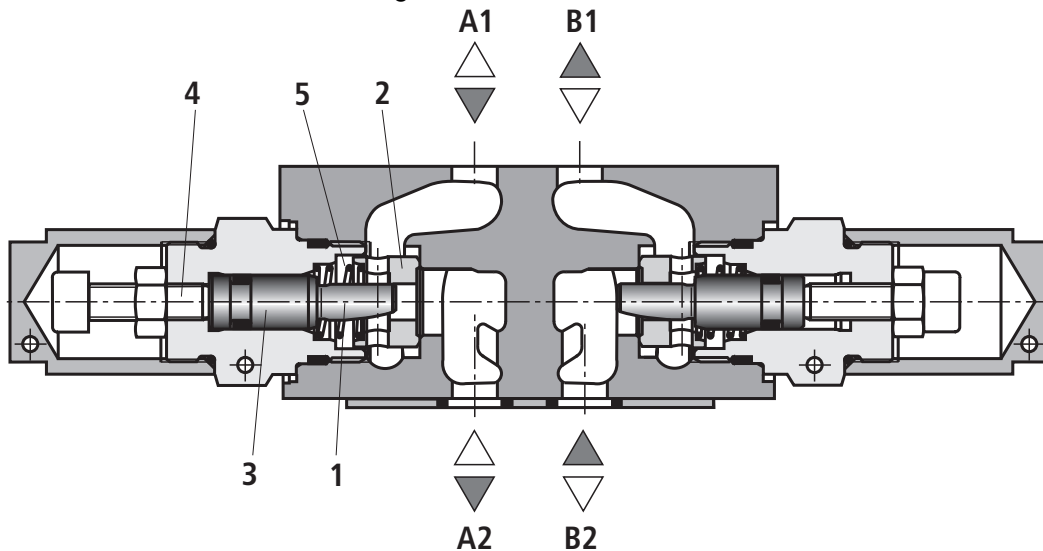

Symbols (1) unit side, (2) plate side

Z2FS 6 -.-4X/S...XC (inlet throttling)

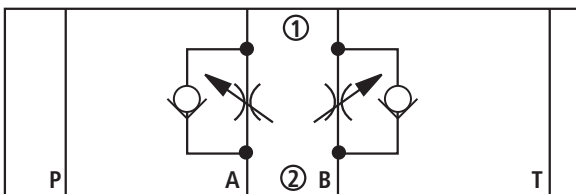

Z2FS 6 -.-4X/S2...XC (outlet throttling)

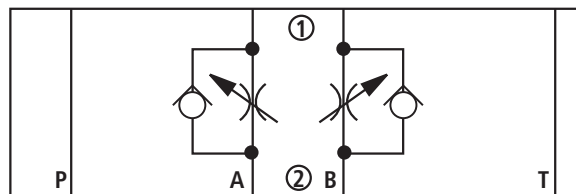

Z2FS 6 A..-4X/S2...XC (outlet throttling)

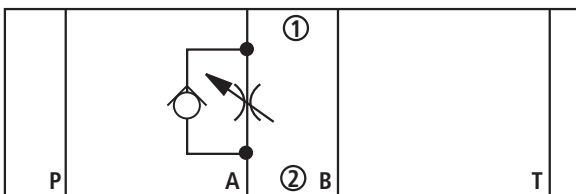

Z2FS 6 B..-4X/S...XC (inlet throttling)

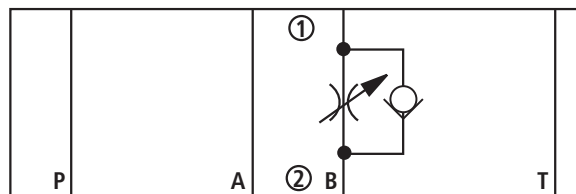

Technical data

General

Installation position		Optional
Ambient temperature range	°C	-20 ... +80 (FKM-seals) -30 ... +80 (NBR-seals)
Storage temperature range	°C	-20 ... +80 (FKM-seals) -30 ... +80 (NBR-seals)
Weight	kg	0,8
Surface protection		Galvanized and chromated olive green FeZn12Dd DIN 50961

Hydraulic

Maximum operating pressure, primary	bar	315
Maximum flow rate	l/min	80
Maximum leakage at 315 bar pressure difference	l/min	1 (through closed throttle)
Pressure fluid		Mineral oil (HL, HLP) to DIN 51524 other pressure fluids available on request Ignition temperature > 180 °C
Pressure fluid temperature range	°C	-20 ... +80 (FKM-seals) -30 ... +80 (NBR-seals)
Viscosity range	mm ² /s	10 ... 800 (preferably 30 ... 60)
Maximum permissible degree of contamination of pressure fluid Purity class to ISO 4406 (c)		Class 20/18/15 ¹⁾

Information on explosion protection

Range of application as per Directive 94/9/EG	IM2, II2G	II2D
Type of protection of valve	c (EN 13463-5:2004-03)	c (EN 13463-5:2004-03)
Maximum surface temperature ²⁾	°C	100
Temperature class	T4	-
Degree of protection	-	IP 67

¹⁾ The purity classes stated for the components must be complied with in hydraulic systems. Effective filtration prevents problems and also extends the service life of components. For a selection of filters, see Technical Data Sheets RE 50070, RE 50076 and RE 50081.

²⁾ As high surface temperatures may occur, European standards ISO 13732-1 and EN 982 on the prevention of accidental contact must be observed

Characteristic curves (measured with HLP46, $\vartheta_{oil} = 40\text{ °C} \pm 5\text{ °C}$)

Δp - q_v curves for Z2FS 6...-4X/.2QXCJ

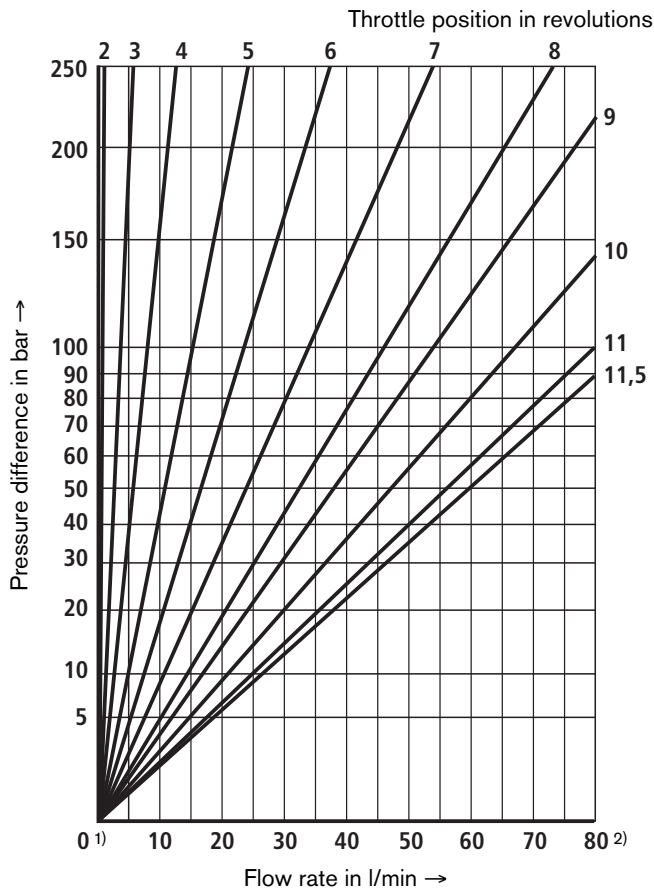

Δp - q_v curves for Z2FS 6...-4X/.1QXCJ

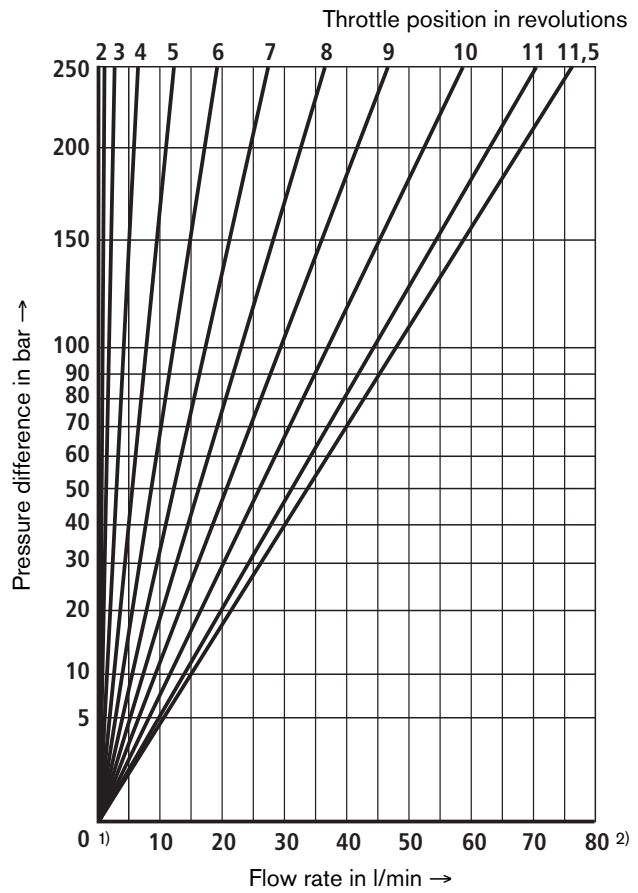

1) Clockwise to stop

2) Anti-clockwise to stop

Δp - q_v curves for Z2FS 6... via check valve when throttle is closed

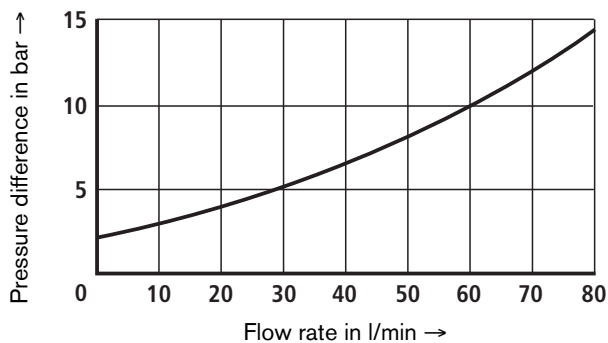

Unit dimensions (in mm)

Type Z2FS 6 -2-4X/S...XC (inlet throttling)

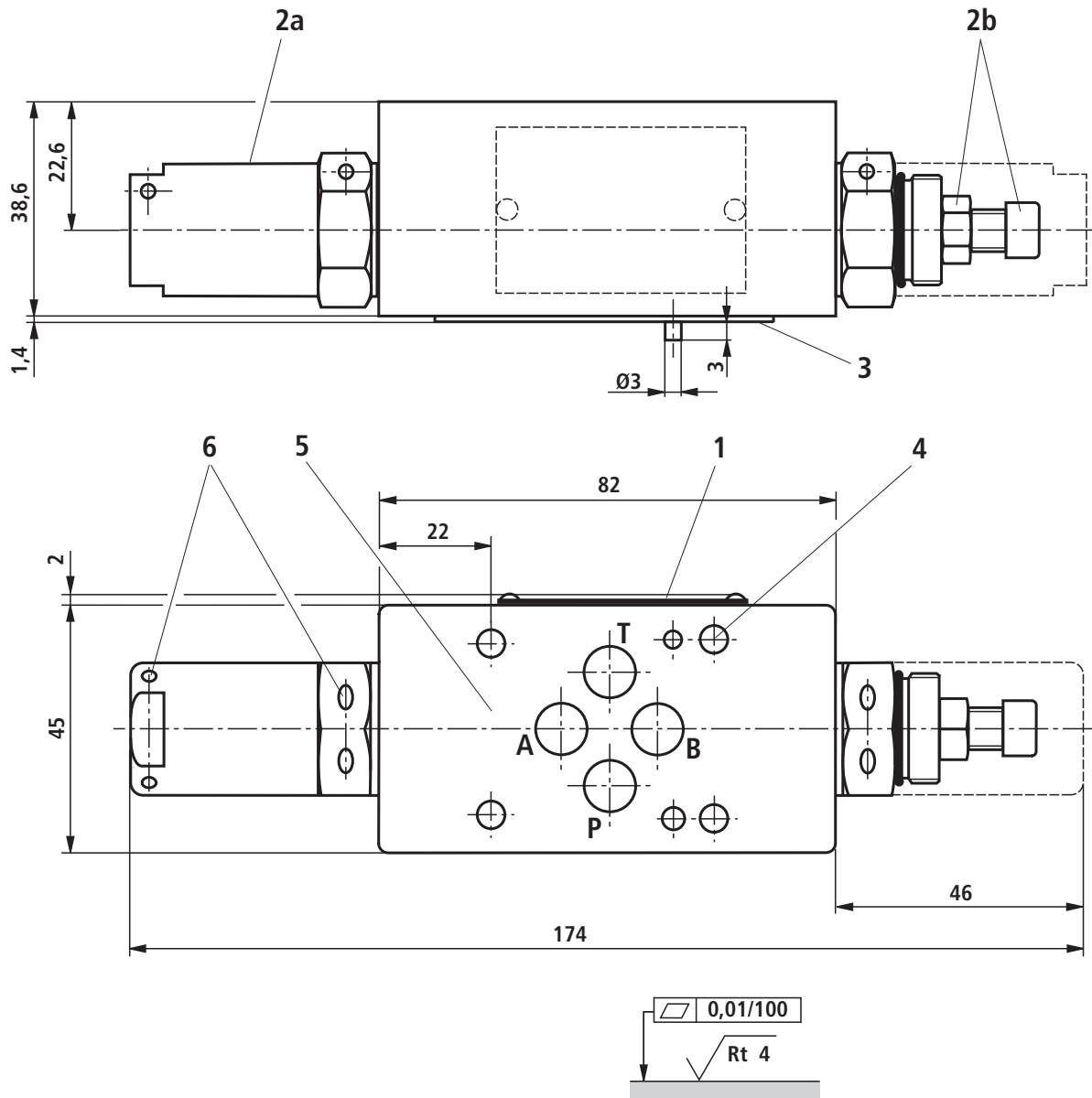

Required surface quality of mating component

- 1 Nameplate
- 2a Protective cap SW20
- 2b Hexagon socket adjusting screw SW5 and lock nut SW10
- 3 Sealing ring plate with identical sealing rings for ports P, A, B, T
- 4 Valve mounting bores
- 5 Position of ports to ISO 4401-03-02-0-05, with locating bore and tension pin $\varnothing 3$ mm
- 6 Bore for lead sealing by customer. Unless the lead seal is destroyed, the valve can no longer be moved.

Valve fastening bolts

In order to ensure a secure connection, use only the following valve fastening bolts:

4 hexagon socket head cap screws

ISO 4762-M5x...-10.9-flZn-240h-L

(coefficient of friction 0.09–0.14 to VDA 235-101)

(must be ordered separately, also see RE 27506-XC-B3, section 9.1, Available accessories)